



LCD MODULE SPECIFICATION

Customer: _____
Model Name: HC101IK25050-D59V.C
Date: 2022.08.31
Version: 03

- Preliminary Specification
 Final Specification

For Customer's Acceptance

Approved by	Comment

Approved by	Reviewed by	Prepared by

Record of Revision

Version	Revise Date	Page	Content
Pre-Spec.01	2022.01.20	All	Initial Release
Pre-Spec.02	2022.06.27	3	Update the PIN
Pre-Spec.03	2022.08.31	3	Update the PIN

TABLE OF CONTENTS

No.	CONTENTS	PAGE
	REVISION STATUS.....	2
	TABLE OF CONTENTS.....	3
1.	GENERAL DESCRIPTION.....	4
2.	MECHANICAL SPECIFICATION	5
3.	PIN DESCRIPTION.....	6
4.	ELECTRICAL CHARACTERISTICS	10
5.	DC CHARCTERISTICS	11
6.	TIMING Characteristics.....	13
7.	BACK LIGHT UNIT	17
8.	Optical Characteristics.....	18
9.	RELIABILITY TEST ITEMS.....	20
10.	HANDING CAUTIONS	21
11.	PACKAGE DRAWING	22

1. GENERAL DESCRIPTION

1.1 DESCRIPTION

HC101IK25050-D59V.C is a color active matrix thin film transistor (TFT) TN liquid crystal display (LCD) that uses amorphous silicon TFT as a switching device. It is composed of a TFT LCD panel, Driver IC ,FPC and Backlight, This TFT LCD has a 10.1-inch diagonally measured active display area with WSVGA resolution (1,024vertical by 600 horizontal pixel array).

1.2 FEATURES:

No.	Item	Specification	Unit
1	Panel Size	10.1”	inch
2	Number of Pixels	1024×RGB (3) ×600	pixels
3	Active Area	222.72(H)×125.28(V)	mm
4	Pixel Pitch	0.2175(H)×0.2088(V)	mm
5	OutlineDimension	253.72(W)×156.28 (H)×7.6(D)	mm
6	Number of Colors	16.7M	-
7	Display Mode	IPS	-
8	Viewing Direction	80/80/80/80	-
9	LCM Interface	LVDS	
10	Touch Interface	USB	
11	TP Surface treatment	6H	-
12	Backlight	White LED	-
13	Operation Temperature	-20~70	°C
14	StorageTemperature	-20~70	°C

2. MECHANICAL SPECIFICATION

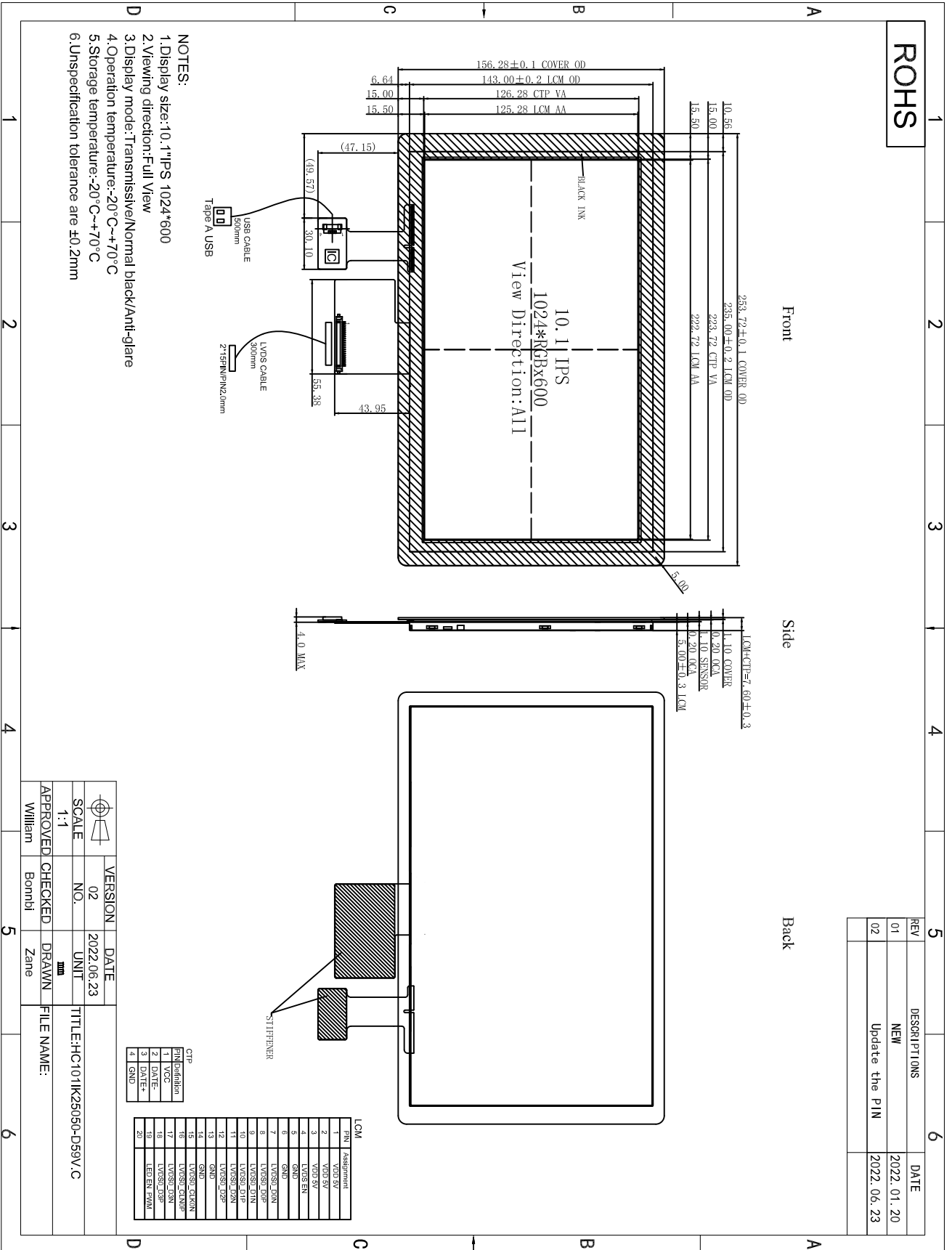

3. Pin Assignment

LCM

Pin No.	Symbol	I/O	Function	Remark
1	VDD	P	Power Voltage for digital circuit (VDD5V)	
2	VDD	P	Power Voltage for digital circuit(VDD5V)	
3	VDD	P	Power Voltage for digital circuit(VDD5V)	
4	LVDS EN	I	LVDS VCC Power EN(Active High)	
5	GND	P	Ground	
6	GND	P	Ground	
7	RXIN0-	I	-LVDS0 differential data input	
8	RXIN0+	I	+LVDS0 differential data input	
9	RXIN1-	I	-LVDS0 differential data input	
10	RXIN1+	I	+LVDS0 differential data input	
11	RXIN2-	I	-LVDS0 differential data input	
12	RXIN2+	I	+LVDS0 differential data input	
13	GND	P	Ground	
14	GND	P	Ground	
15	RXCLKIN-	I	-LVDS0 differential clock input	
16	RXCLKIN+	I	+LVDS0 differential clock input	
17	RXIN3-	I	-LVDS0 differential data input	
18	RXIN3+	I	+LVDS0 differential data input	
19	LED EN PWM	I	Backlight Power EN(Active High) and PWM	
20	NC	I	No Connect	

3.2 Advice circuit for customer system

3.2.1 Power PIN: AVDD/VDD/VGH/VGL

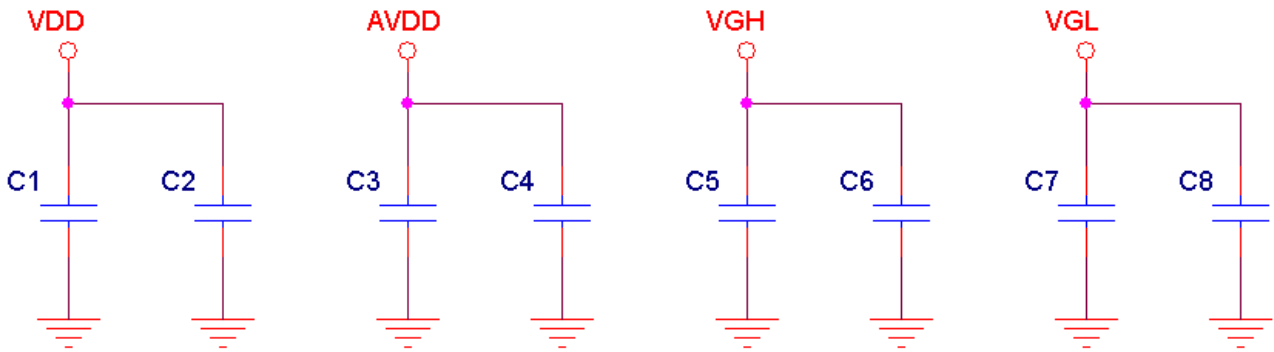

3.2.2 Control PIN: RESET

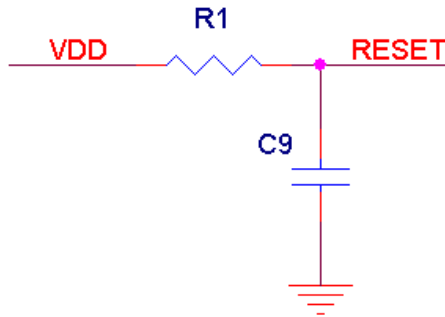

3.2.3 VCOM

Typical VCOM is only a reference value, it must be optimized according to each LCM. Be sure to use VR;

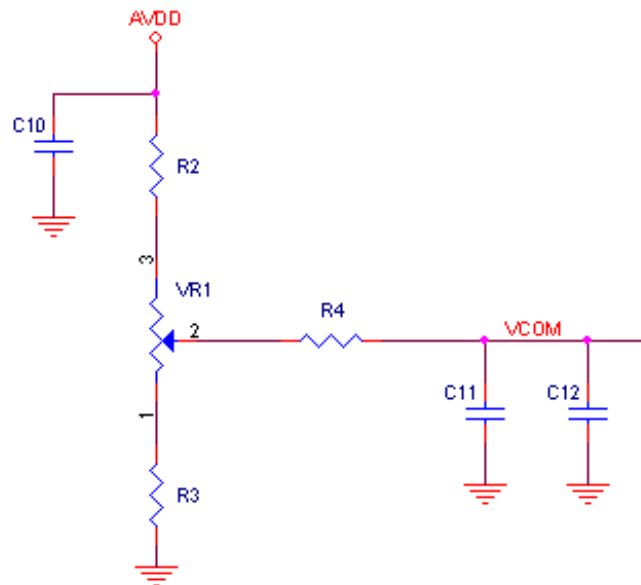

3.2.4 LVDS signal: LVDS terminal resistor

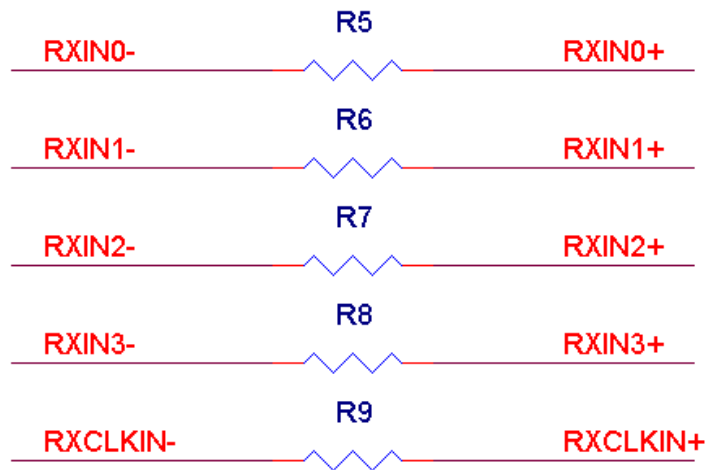

3.2.5 Suggestion BOM

Location	Description
C1,C11	10uF,X5R,10V
C2,C12	100nF,X5R,10V
C3,C7	10uF,X5R,25V
C4,C8	100nF,X5R,25V
C5	10uF,X5R,50V
C6	100nF,X5R,50V
C9	1uF,X5R,10V
C10	1uF,X5R,25V
R1	10Kohm,1%
R2	12Kohm,1%
R3	10Kohm,1%
R4	0ohm,1%
VR1	10Kohm,1%
R5,R6,R7,R8,R9	100ohm,1%

4. ELECTRICAL CHARACTERISTICS

4.1. Absolute Maximum Ratings

Item	Symbol	Min.	Max.	Unit	Remark
Power Supply Voltage	VDD	-0.3	5.5	V	
Storage temperature	Tstg	-20	+70	°C	
Operating Temperature	Topr	-20	+70	°C	

Note:

- (1) All of the voltages listed above are with respect to GND= 0V
- (2) Device is subject to be damaged permanently if stresses beyond those absolute maximum ratings listed above.

5. DC CHARACTERISTICS

5.1 Parameter

Item	Symbol	Value			Units	Remark
		Min	Typ	Max		
Power supply voltage	VDD	3.3	5	5.5	V	
Input signal voltage	VCOM	4.39	5.39	6.39	V	
Logic high level input voltage	VIH	0.7xVDD	-	VDD	V	Note 1
Logic low level input voltage	VIL	VSS	-	0.3xVDD	V	

(Ta = 25 ± 2°C)

Note 1: Including signal: U/D、L/R、RESET、STBYB、SELB、CABCEN0、CABCEN1.

5.2 Power Sequence

Power on

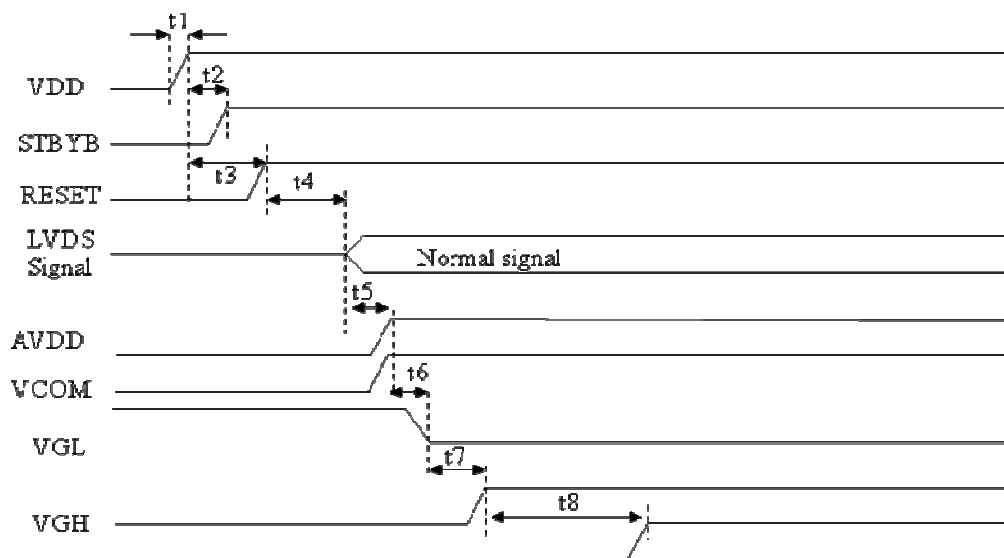

Symbol	SPEC			Unit
	Min.	Typ.	Max.	
t1	1	10	20	ms
t2	20	35	50	us
t3	1	10(RC Delay)	12	ms
t4	30	50	100	ms
t5	0.1	5	20	ms
t6	20	70	120	ms
t7	40	90	140	ms
t8	150	170	200	ms

Power off

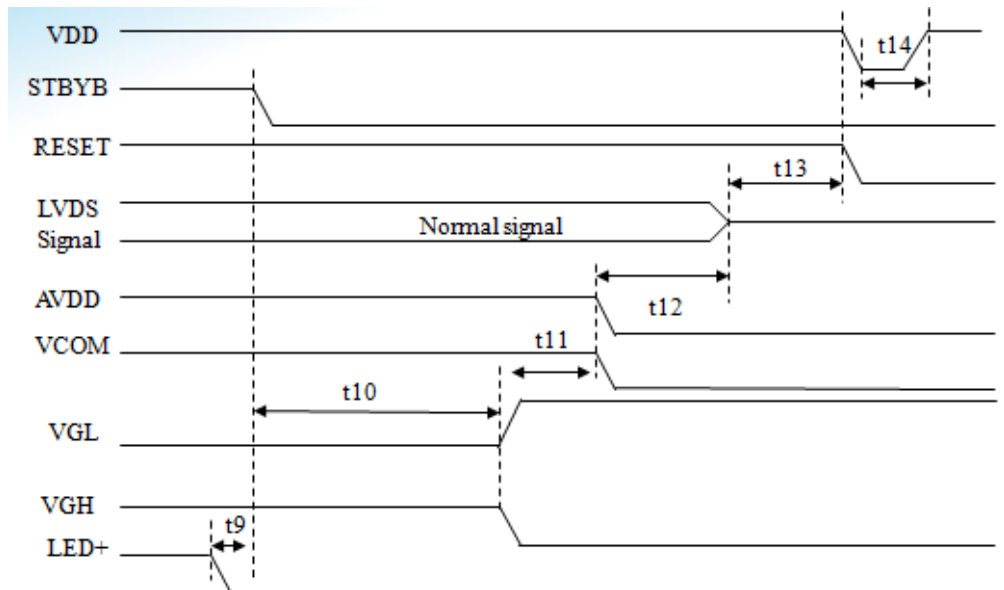

Symbol	SPEC			Unit
	Min.	Typ.	Max.	
t9	0.1	1	10	ms
t10	120	150	200	ms
t11	50	100	200	ms
t12	1	10	20	ms
t13	0.1	10	100	ms
t14	500	-	-	ms

6. Timing Characteristics

6.1 AC Electrical Characteristics

Parameter	Symbol	Min	Typ	Max	Units	Condition
Clock frequency	RxFCLK	26.2	51.2	71	MHz	
Input data skew margin	TRSKM	500	500	$1/(2 \cdot RxFCLK)$	ps	Typical value for 1024*600 resolution
Clock high time	TLVCH	$4/(7 \cdot RxFCLK)$			ns	$ VID =400\text{mv}$ $RxVCM=1.2\text{V}$ $RxFCLK=71\text{MHz}$ $VDD_LVDS=3.3\text{V}$
Clock low time	TLVCL	$3/(7 \cdot RxFCLK)$			ns	
VSD setup time	TenPLL	$0 < TenPLL < 150$			us	

6.2 Input Clock and Data Timing Diagram

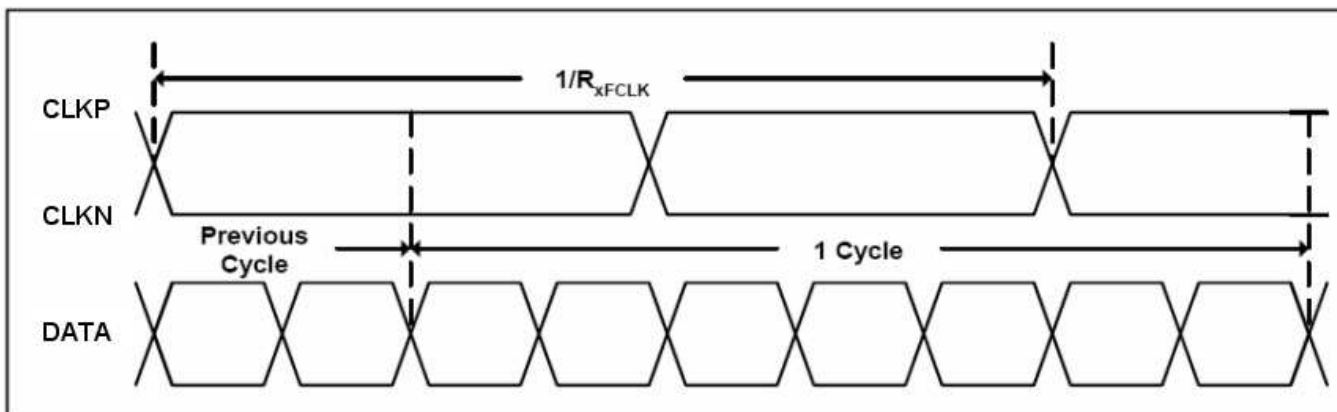

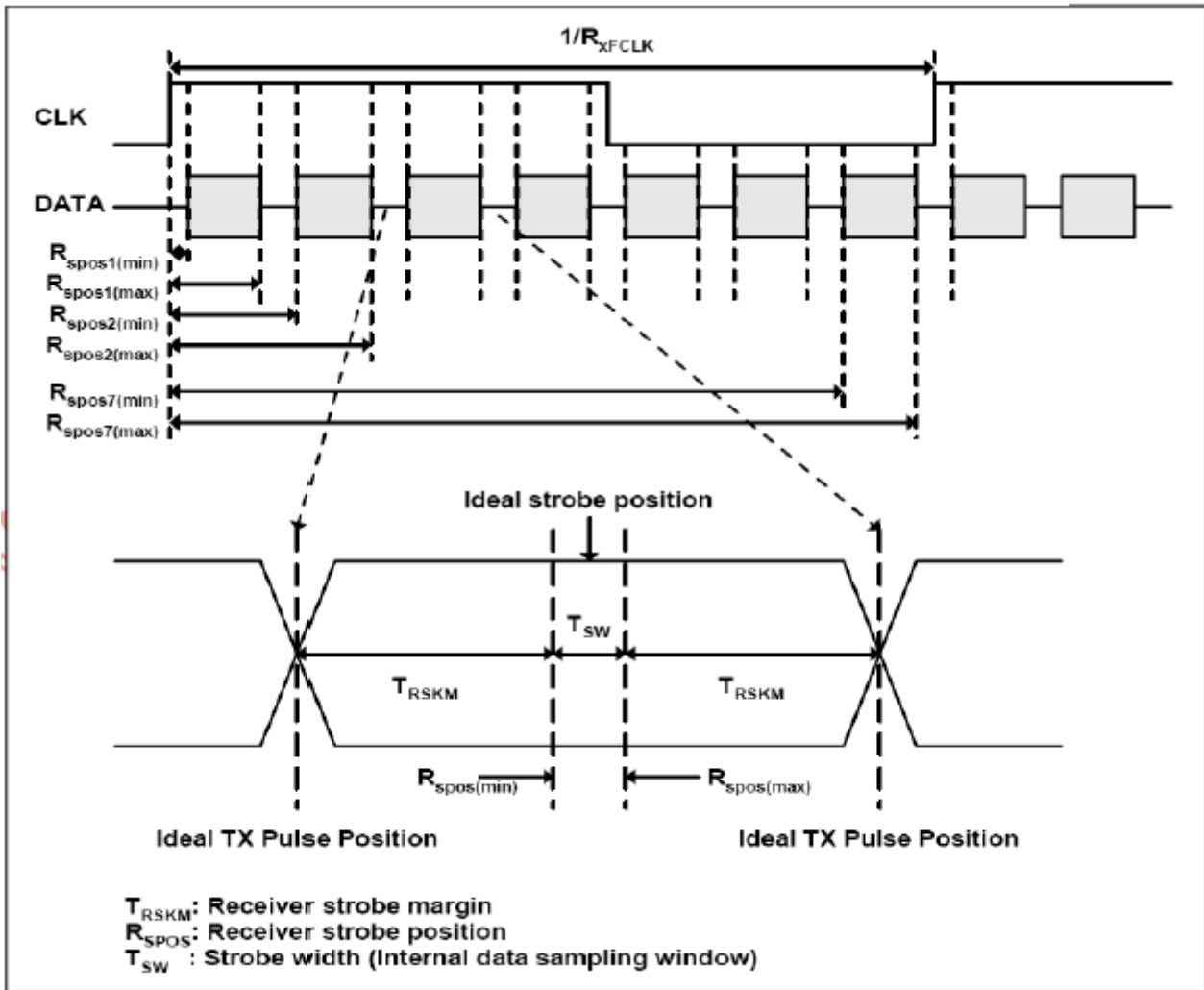

6.3 Electrical Characteristics

Parameter	Symbol	Min	Typ	Max	Units	Condition
Differential input high threshold voltage	RxVTH	0.1	0.2	VID	V	RxVCM=1.2V
Differential input low threshold voltage	RxVTL	- VID	-0.2	-0.1	V	
Input voltage range (singled-end)	RxVIN	0	1.2±0.4	2.4	V	
Differential input common mode voltage	RxVCM	VID /2	1.2	2.1- VID /2	V	
Differential input voltage	VID	0.2	0.4	0.6	V	
Differential input leakage current	RVxliz	-10	0	+10	uA	

LVDS Digital Operating Current	I _{ddlvs}	8	22	30	mA	F _{clk} =65MHz, V _{DD} =3.3V
LVDS Digital Standby Current	I _{stlvs}	0	200	300	uA	Clock & all Functions are stopped
LVDS Differential impedance	Z _{diff}	90	100	110	ohm	R _{XINx} +/-, R _{XINCLK} +/-

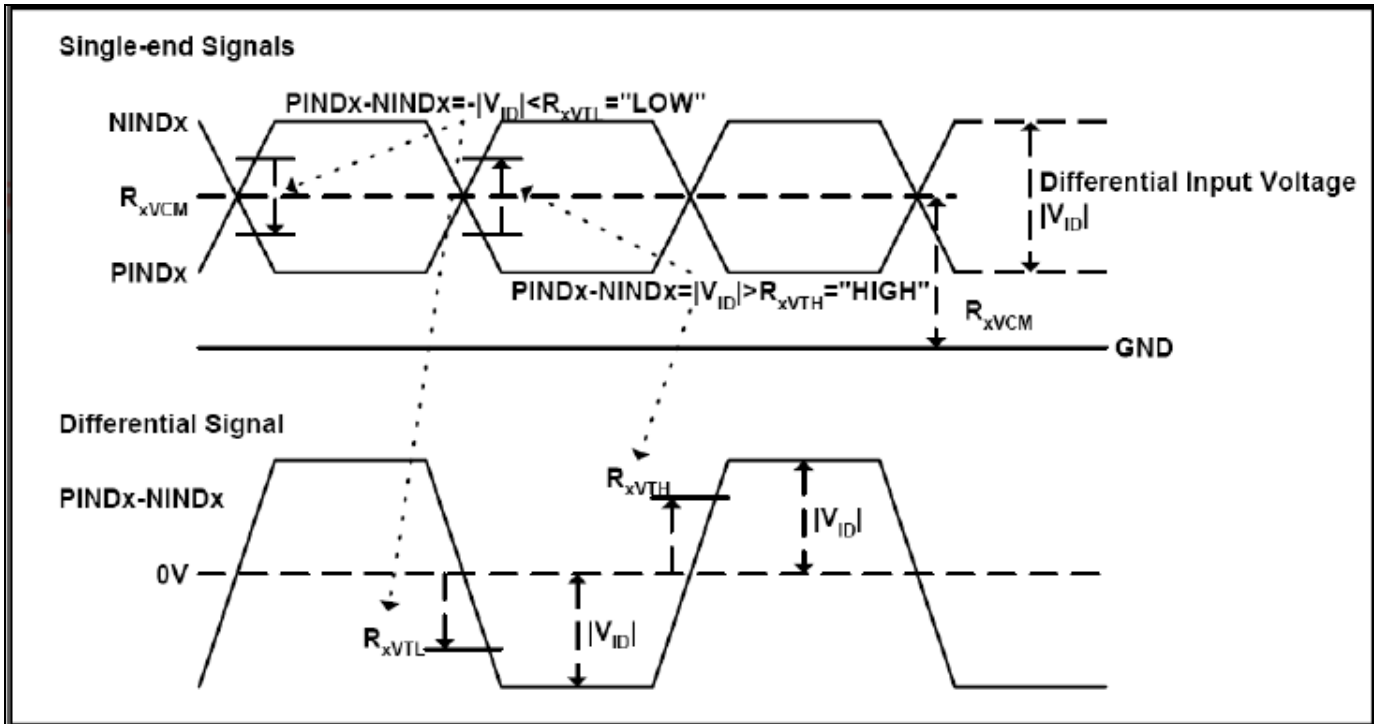

6.4 Timing

Parallel	Symbol	Vaule			Unit
		Min	Typ	Max	
DCLK Frequency Frame rate=60Hz	fclk	42.5	51.2	67.2	MHz
Horizontal display area	thd	1024			DCLK
HSYNC period time	thpw	1164	1344	1400	DCLK
HSYNC blanking	thb+thfp	140	320	376	DCLK
Vertical display area	tvd	600			H
VSYNC period time	tvpw	610	635	800	H
VSYNC blanking	tvb+tvfp	10	35	200	H

6.5 Data Input Format

6bit LVDS input

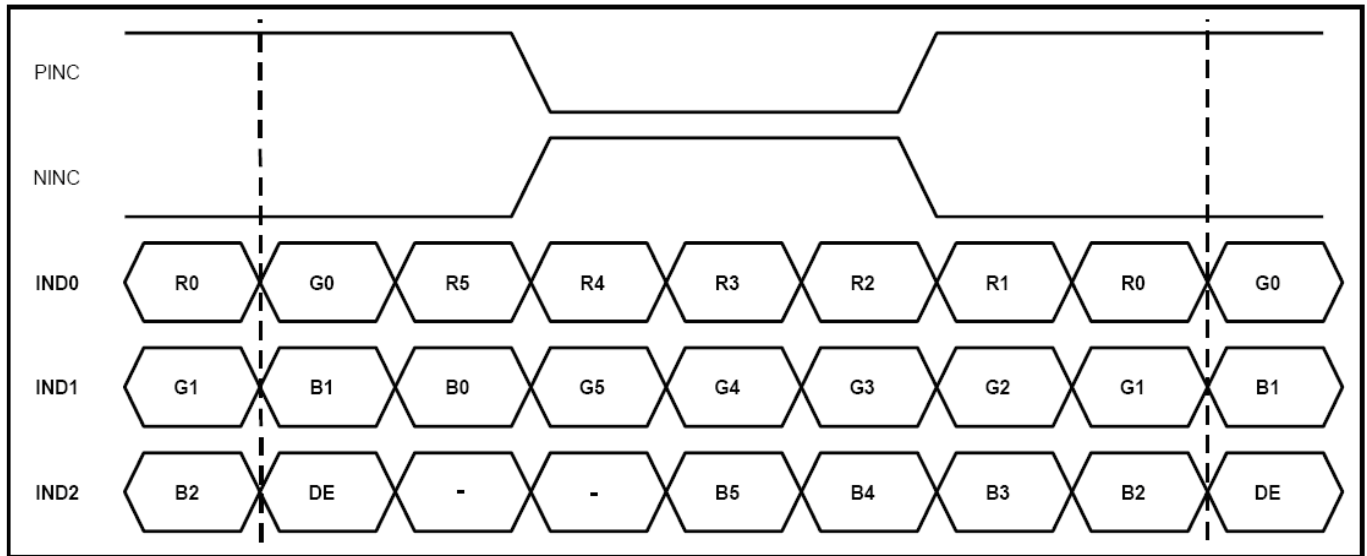

8bit LVDS input

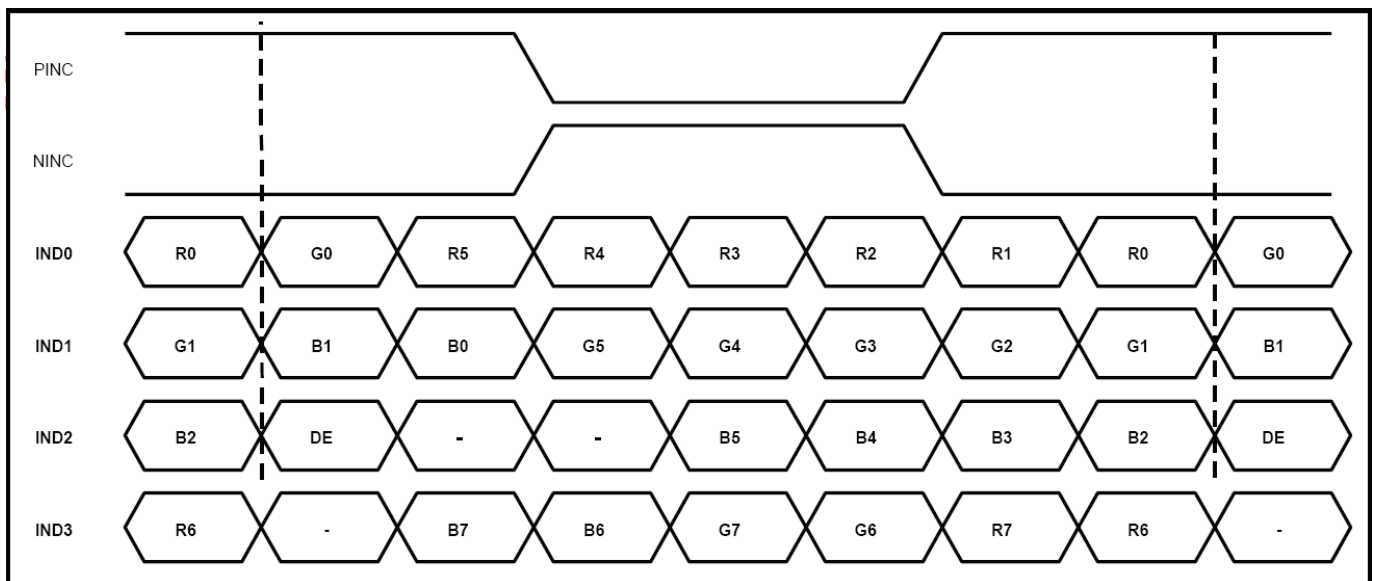

7. BACK LIGHT UNIT

Item	Symbol	Values			Unit	Remark
		Min.	Typ.	Max.		
Voltage for LED backlight	V_L	9.0	9.3	10.5	V	Note 1
Current for LED backlight	I_L	-	220	-	mA	
LED life time	-	50000	-	-	Hr	Note 2

Note 1: The LED Supply Voltage is defined by the number of LED at $T_a=25^{\circ}\text{C}$ and $I_L = 220\text{mA}$.

Note 2: The "LED life time" is defined as the module brightness decrease to 50% original brightness at $T_a=25^{\circ}\text{C}$ and $I_L = 220\text{mA}$. The LED lifetime could be decreased if operating I_L is larger than 220mA.

8. OPTICAL CHARACTERISTICS

Item	Symbol	Condition	Values			Unit	Remark
			Min.	Typ.	Max.		
Viewing angle (CR≥ 10)	θ_L	$\Phi=180^\circ$ (9 o'clock)	75	80	-	degree	Note 1
	θ_R	$\Phi=0^\circ$ (3 o'clock)	75	80	-		
	θ_T	$\Phi=90^\circ$ (12 o'clock)	75	80	-		
	θ_B	$\Phi=270^\circ$ (6 o'clock)	75	80	-		
Response time	T_{ON}	Normal $\theta=\Phi=0^\circ$	-	10	20	msec	Note 3
	T_{OFF}		-	15	30	msec	Note 3
Contrast ratio	CR		600	800	-	-	Note 4
Color chromaticity	W_X		0.26	0.36	0.38	-	Note 2 Note 5 Note 6
	W_Y		0.28	0.38	0.39	-	
Luminance	L		-	250	-	cd/m ²	Note 6
Luminance uniformity	Y_U		75	80	-	%	Note 7

Test Conditions:

..

(1) Driving voltage

Based on item 5. DC CHARACTERISTICS and 6. AC CHARACTERISTICS

(2) Ambient temperature: $T_a=25^\circ\text{C}$

(3) Testing point: measure in the display center point and the test angle $\Theta=0^\circ$

(4) Testing Facility: Environmental illumination: ≤ 1 Lux

Note 8-1: Viewing angle diagrams

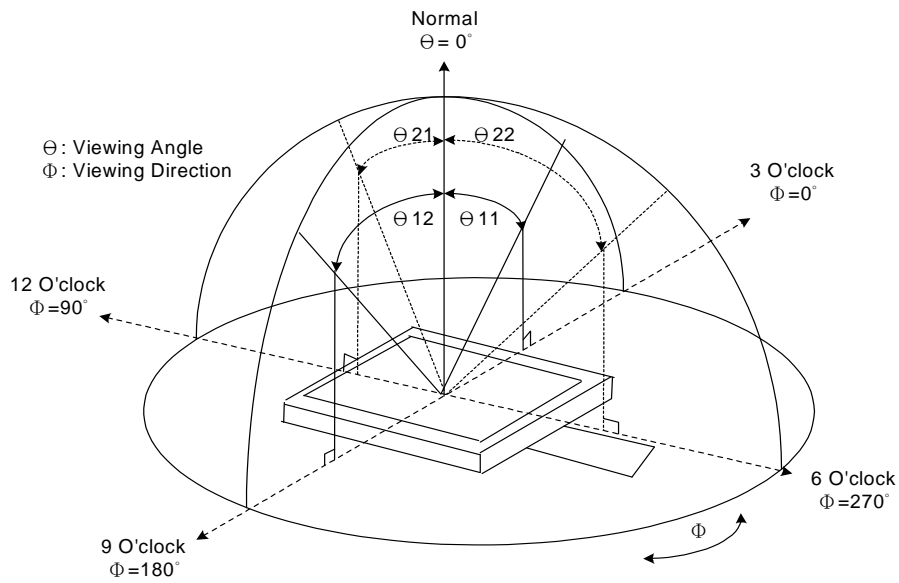

Note 8-2: Response time

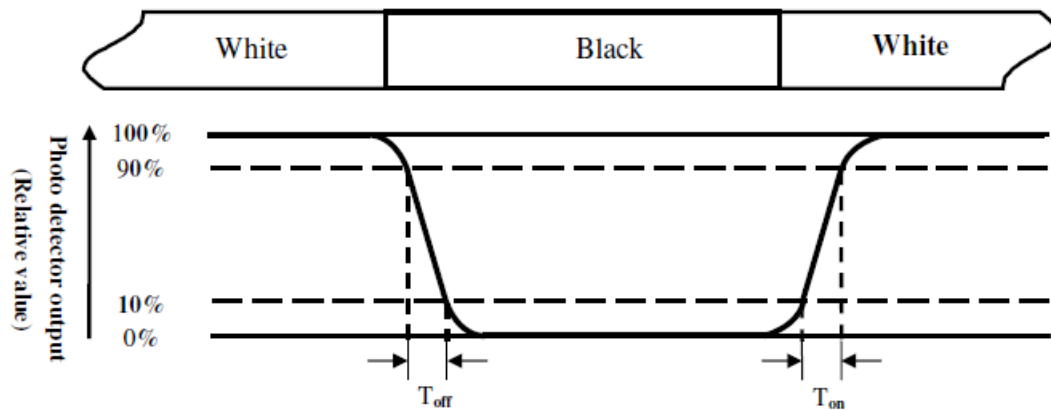

Note 8-3: Transmittance

The transmittance is measured on INX stabilized backlight.

Note 8-4: Contrast ratio

The contrast ratio can be calculated by the following expression.

$$\text{Contrast Ratio (CR)} = \text{White} / \text{Black}$$

Note 8-5 Chromaticity

The chromaticity is measured in CIE 1931 at the center point of C Light Source.

9. RELIABILITY TEST ITEMS

No.	Test Items	Test Condition	Note
1	High Temperature Storage	70°C, 240hrs	Note 1, 2
2	Low Temperature Storage	-20°C, 240hrs	Note 1, 2
3	High Temperature Operation	70°C, 240hrs	Note 1, 2
4	Low Temperature Operation	-20°C, 240hrs	Note 1, 2
5	High Temperature and High Humidity Storage	60°C, 90%RH, 240hrs	Note 1, 2
6	Thermal Shock	-10°C/0.5h ~ +60°C/0.5h for a total 100 cycles	Note 1, 2
7	Electro Static Discharge	C=150pF, R=330Ω, 5point/panel Air:±4Kv, 5times	Note 2
8	Package Drop Test	Height:60cm, 1 corner, 3 edges, 6 surfaces	Note 2

Note 1: The test samples have recovery time for 2 hours at room temperature before the function check. In the standard conditions, there is no display function NG issue occurred.

Note 2: After the reliability test, the product only guarantees operation, but don't guarantee all of the cosmetic specification.

10. HANDLING CAUTIONS

10.1 ESD (Electrical Static Discharge) strategy

ESD will cause serious damage of the panel, ESD strategy is very important in handling. Following items are the recommended ESD strategy

- (1) In handling LCD panel, please wear gloves with non-charged material. Using the conduction ring connects wrist to the earth and the conducting shoes to the earth necessary is.
- (2) The machine and working table for the panel should have ESD protection strategy.
- (3) In handling the panel, ionized airflow decreases the charge in the environment is necessary.
- (4) In the process of assemble module, shield case should connect to the ground.

10.2 Environment

- (1) Working environment of the panel should be in the clean room.
- (2) Because touch panel has protective film on the surface, please remove the protection film slowly with ionized air to prevent the electrostatic discharge.

10.3 Others

- (1) Turn off the power supply before connecting and disconnecting signal input cable.
- (2) Because the connection area of FPC and panel is not so strong, do not handle panel only by FPC or bend FPC.
- (3) Water drop on the surface or condensation as panel power on will corrode panel electrode.
- (4) As the packing bag open, watch out the environment of the panel storage. High temperature and high humidity environment is prohibited.
- (5) In the case the TFT LCD module is broken, please watch out whether liquid crystal leaks out or not. If your hand touches liquid crystal, wash your hands cleanly with water and soap as soon as possible.